

FEIRA DO TROCA

PAVILHÃO CULTURAL LAÍS ADERNE
OLHOS D'ÁGUA



OLHOS D'ÁGUA...









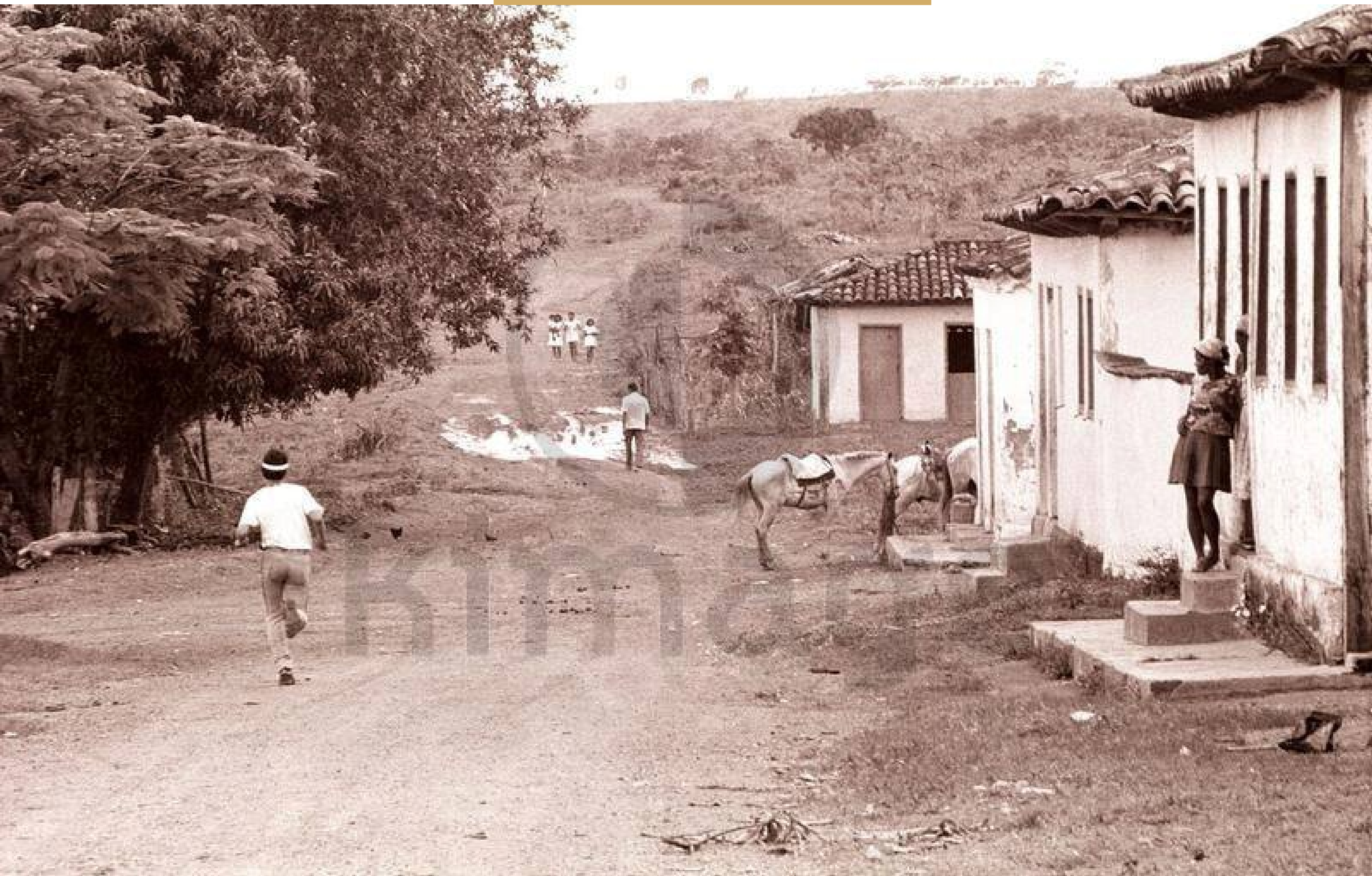









FEIRA DO TROCA

UM CANAL DE RESGATE PARA A PRODUÇÃO
ARTESANAL.



Governo Municipal de
ALEXÂNIA

A FORÇA DO POVO.









Governo Municipal de

ALEXÂNIA

A FORÇA DO POVO.





Governo Municipal de
ALEXÂNIA
A FORÇA DO POVO.





Governo Municipal de
ALEXÂNIA
A FORÇA DO POVO







LAIS ADERNE,
A IDEALIZADORA DA
FEIRA DO TROCA.

MOTIVAÇÃO

A feira do Troca é um marco para a cidade de Alexânia, porém esse evento não possui uma infraestrutura adequada.









Praça para show
3540,57 m²



Cinema Aberto
111,38 m²



Praça para ambulantes
3540,57 m²



Edifício para curso
734,76m²



Pavilhão de Exposição
749,50 m²

O PROGRAMA

O programa foi definido a partir do desenvolvimento da feira do troca.

ÁREA TOTAL - 8676,78M²

ÁREA TOTAL DO TERRENO- 9667,30M²



Urbanismo
Áreas de Descanso

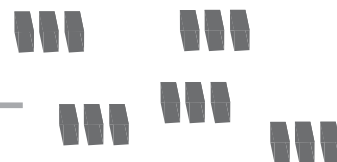

Paisagismo
Áreas Verdes

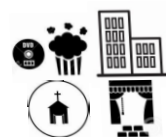
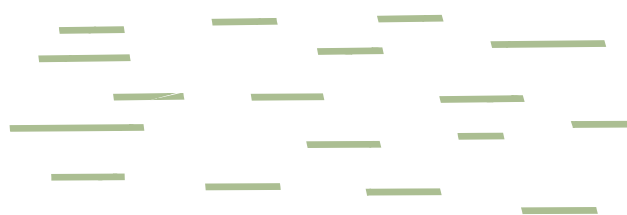

Edificações
Pavilhão, cine,
show, igreja

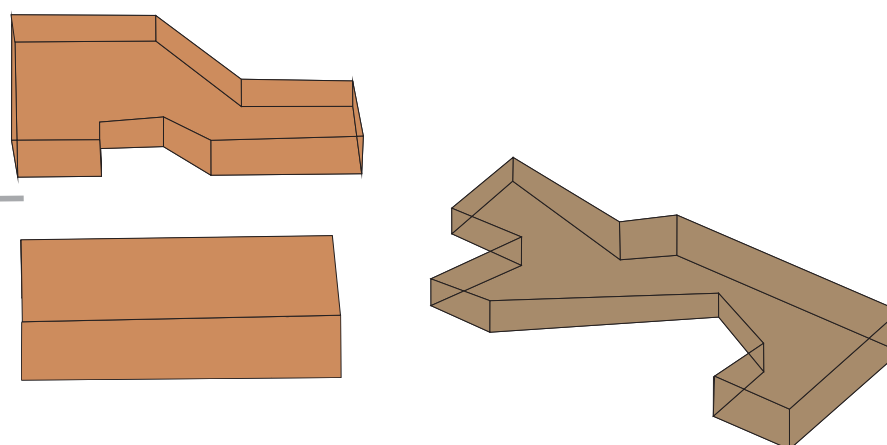

Percurso
Circulação e
Acessos

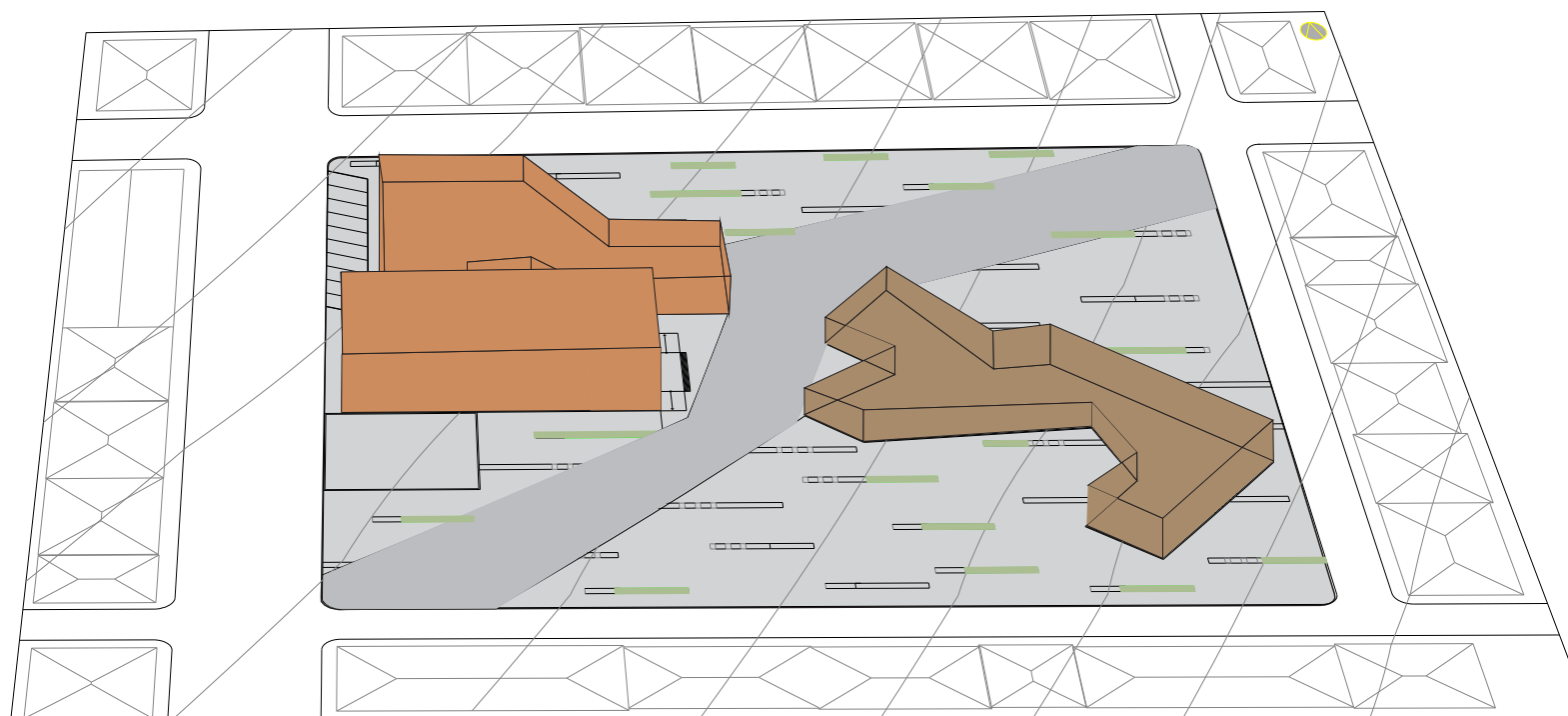

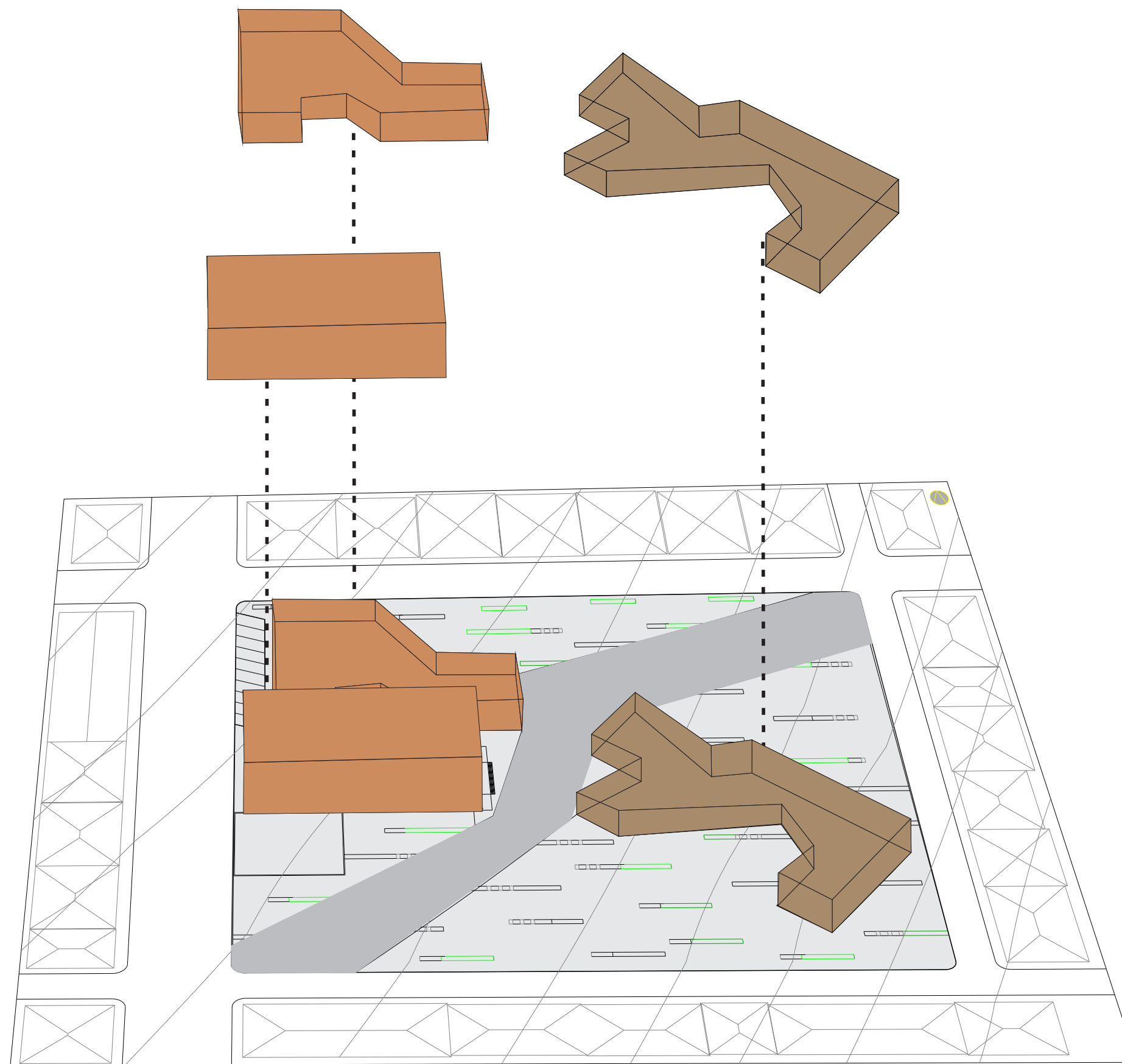

■ Uso Sazonal

■ Uso Continuo



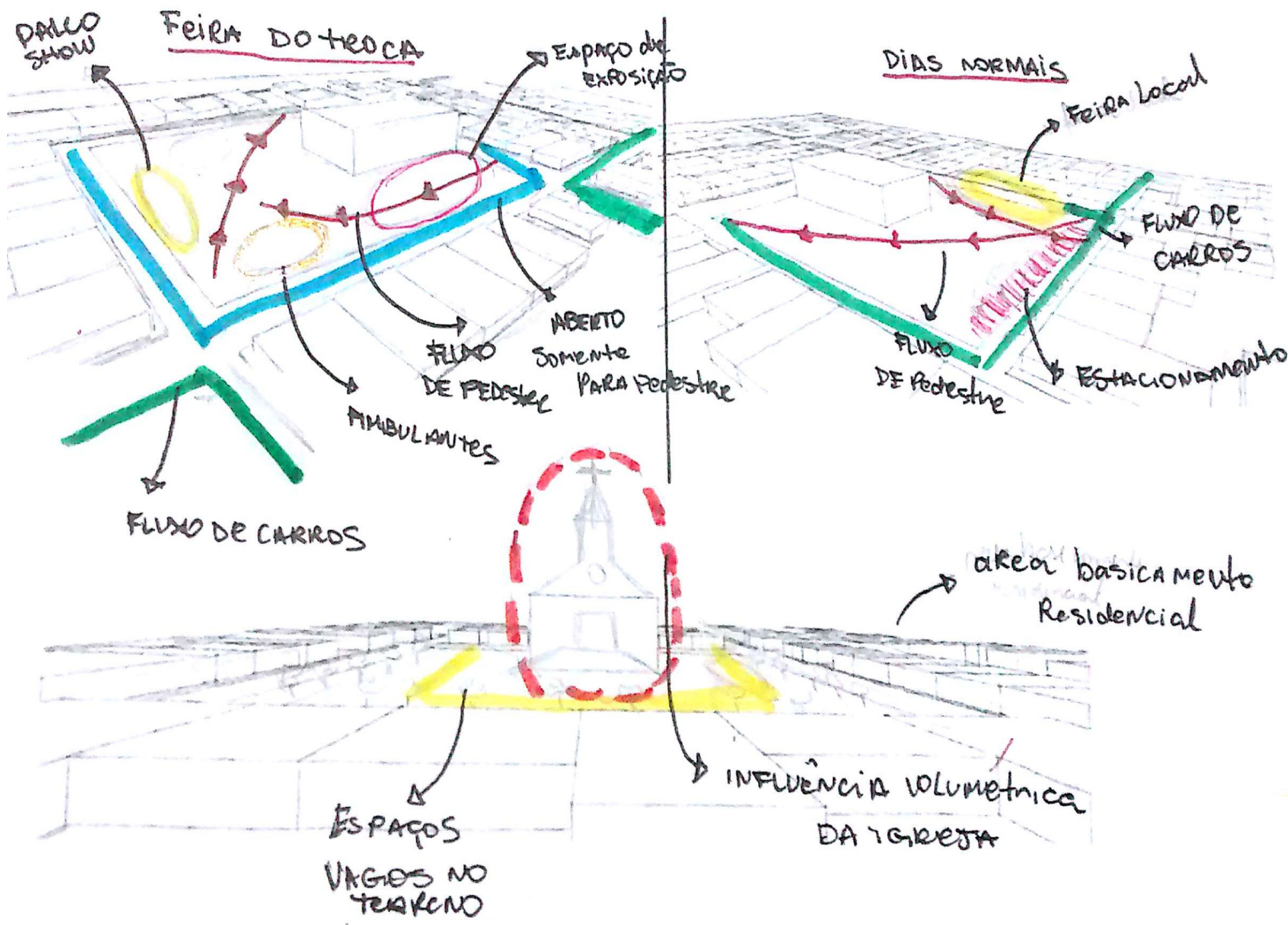

Os caminhos e as articulações funcionais são pensados com base no desenvolvimento da feira do troca.

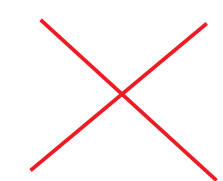
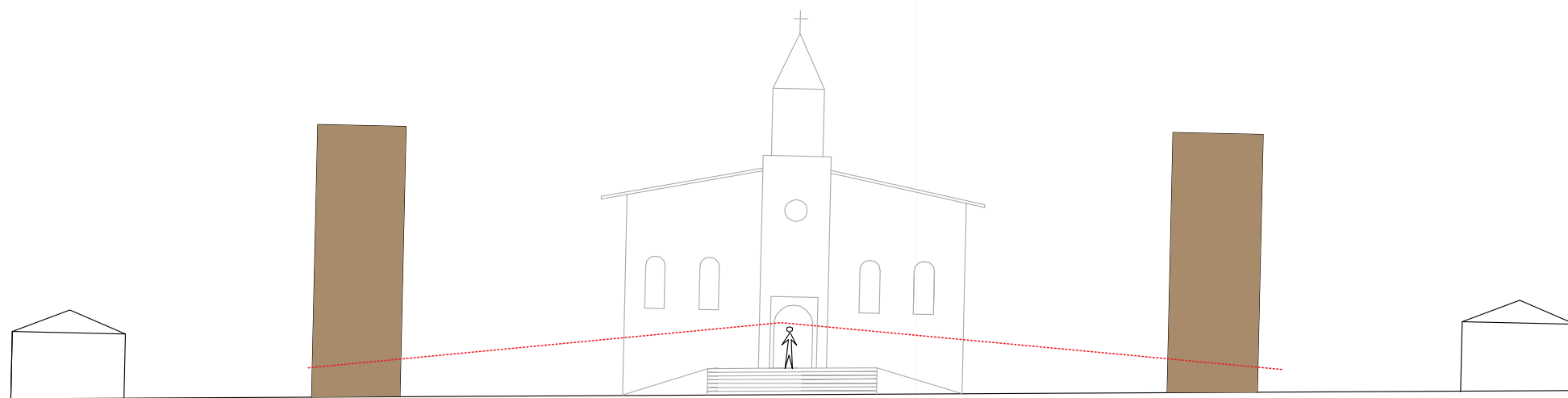

CONCEPÇÃO...

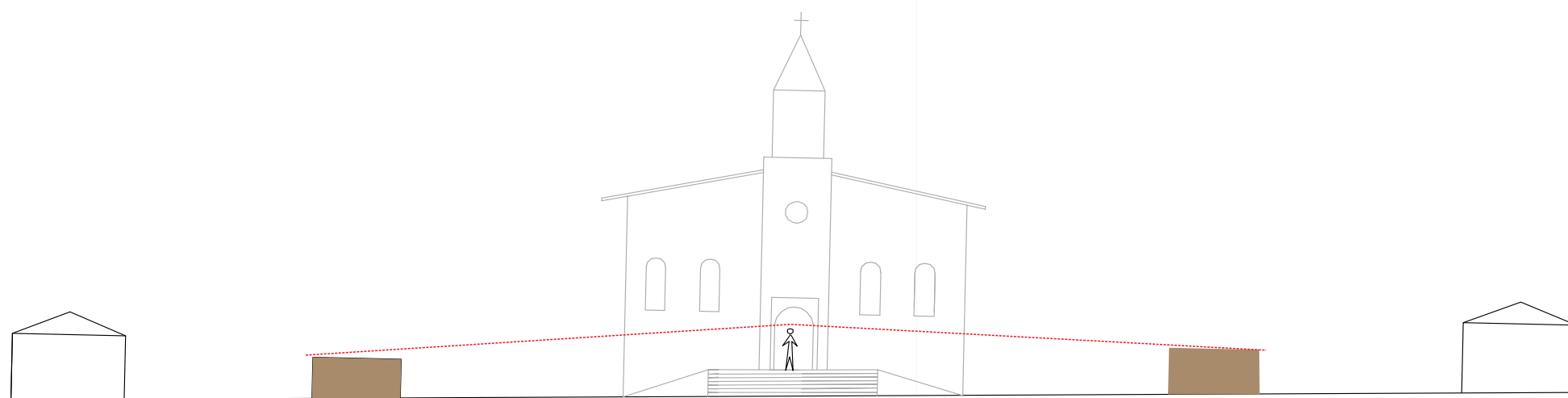

CONCEPÇÃO...

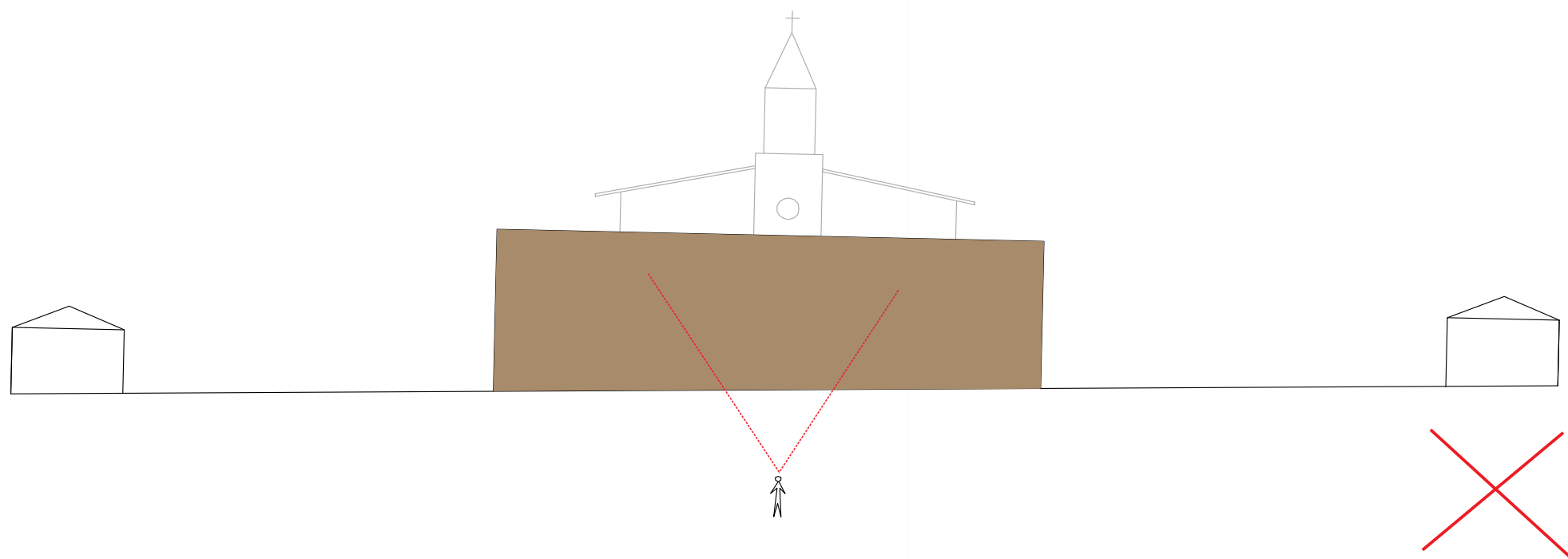

CONCEPÇÃO...

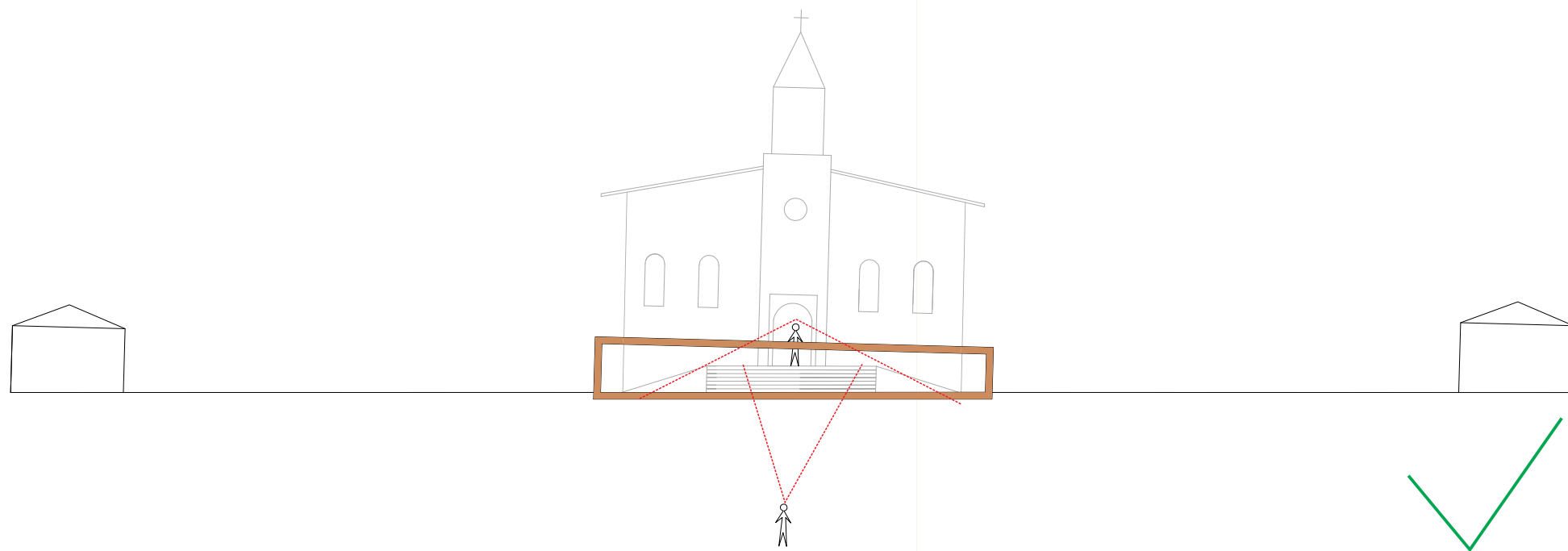

CONCEPÇÃO...

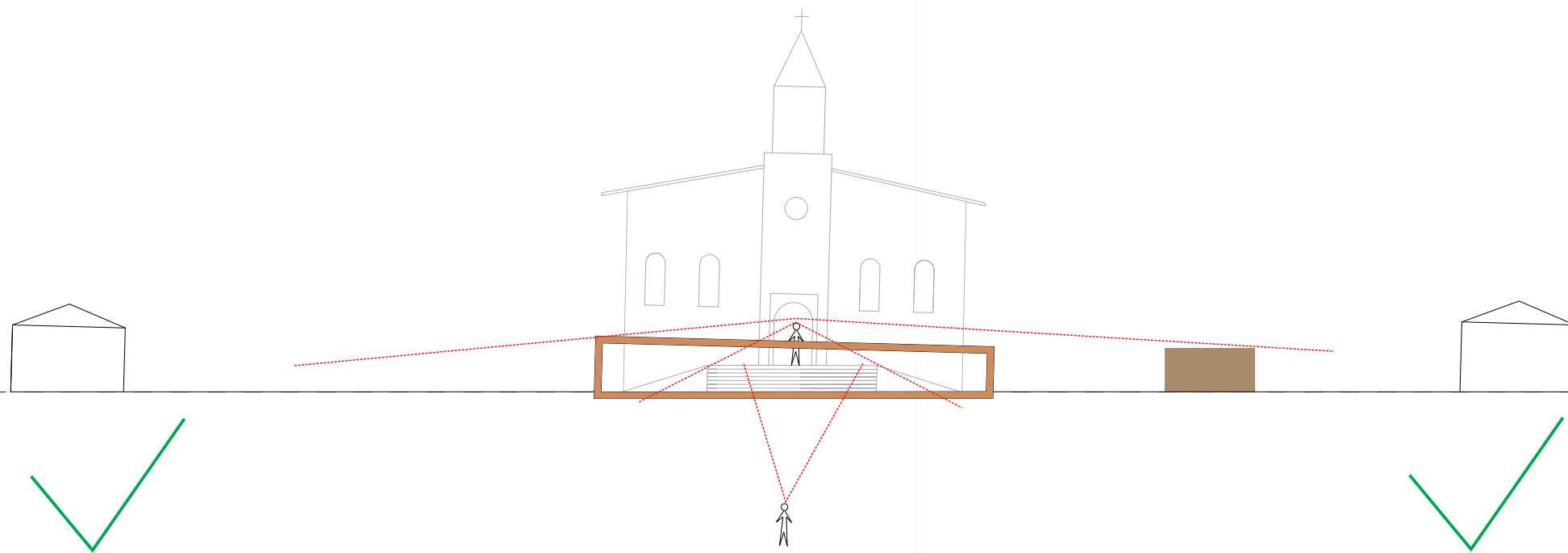

CONCEPÇÃO...

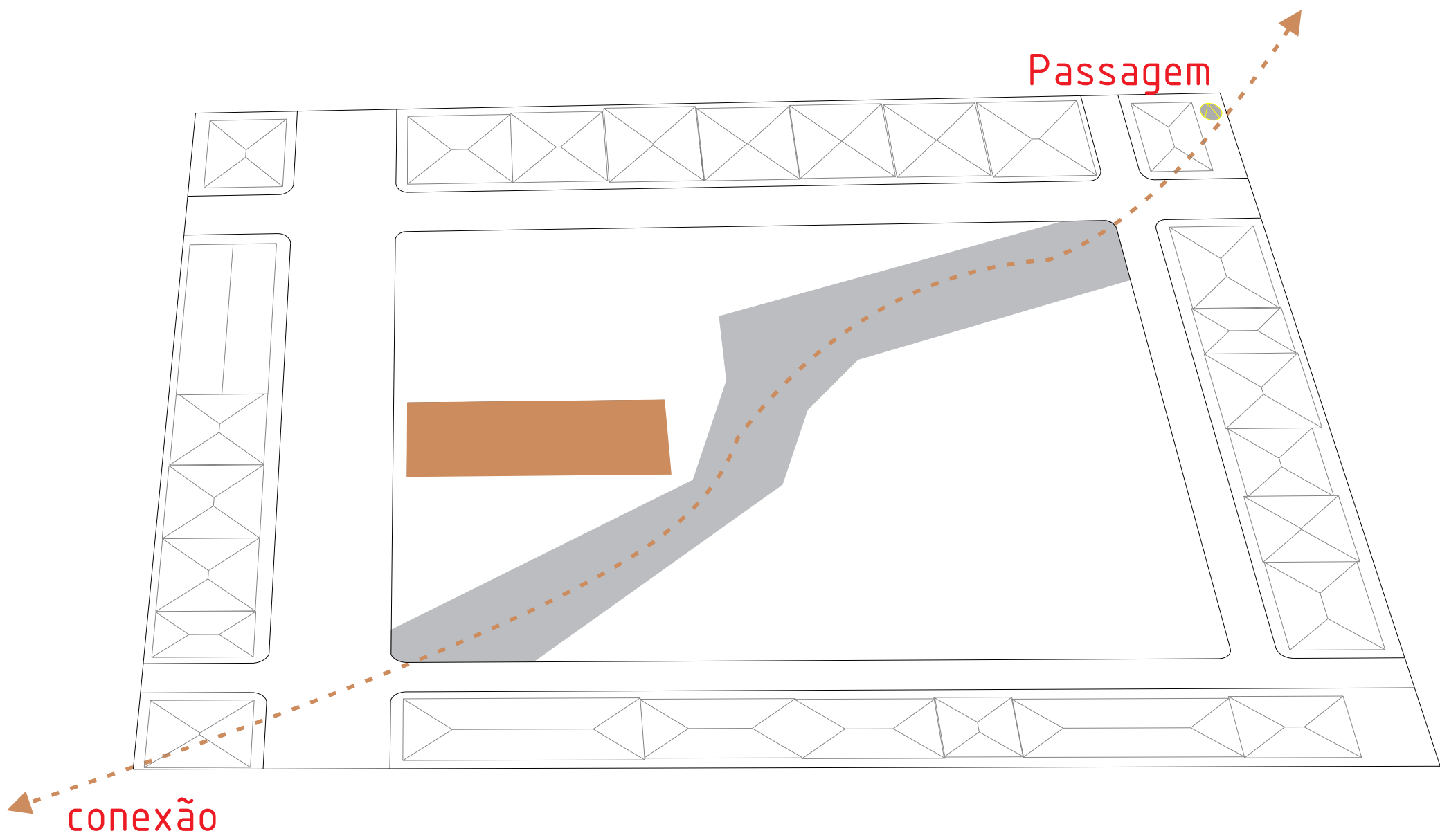

CONCEPÇÃO...

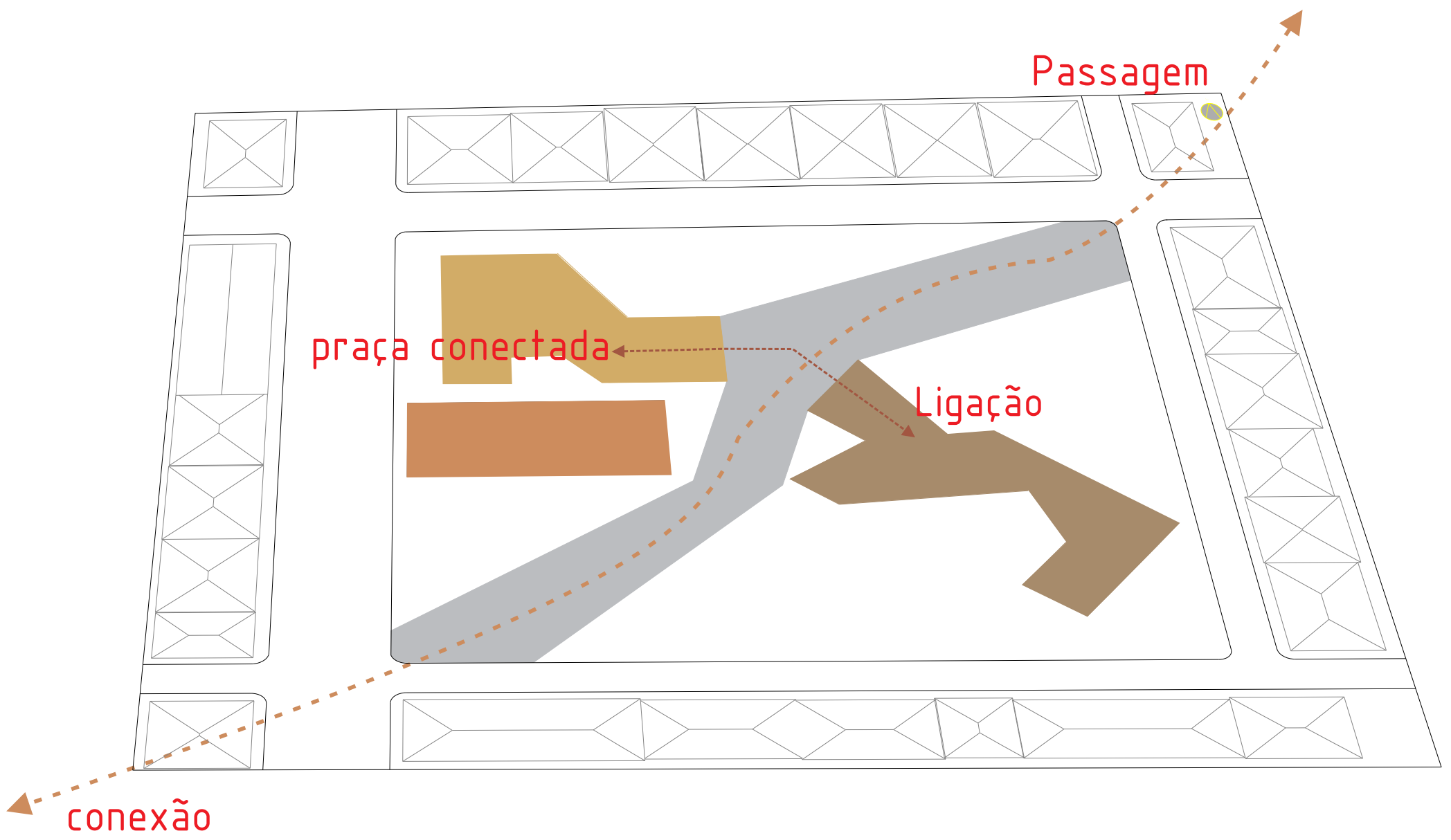

CONCEPÇÃO...

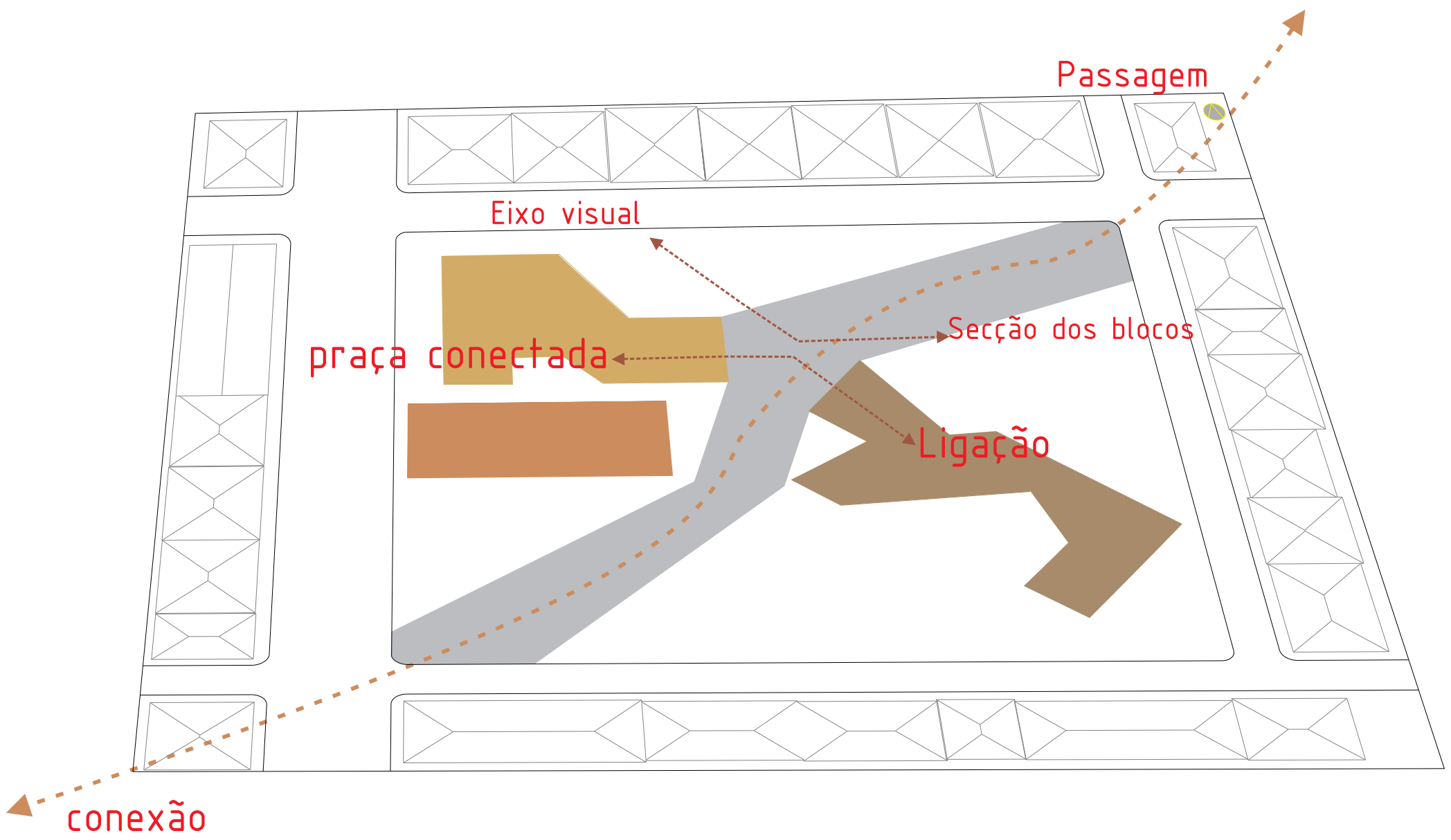

CONCEPÇÃO...

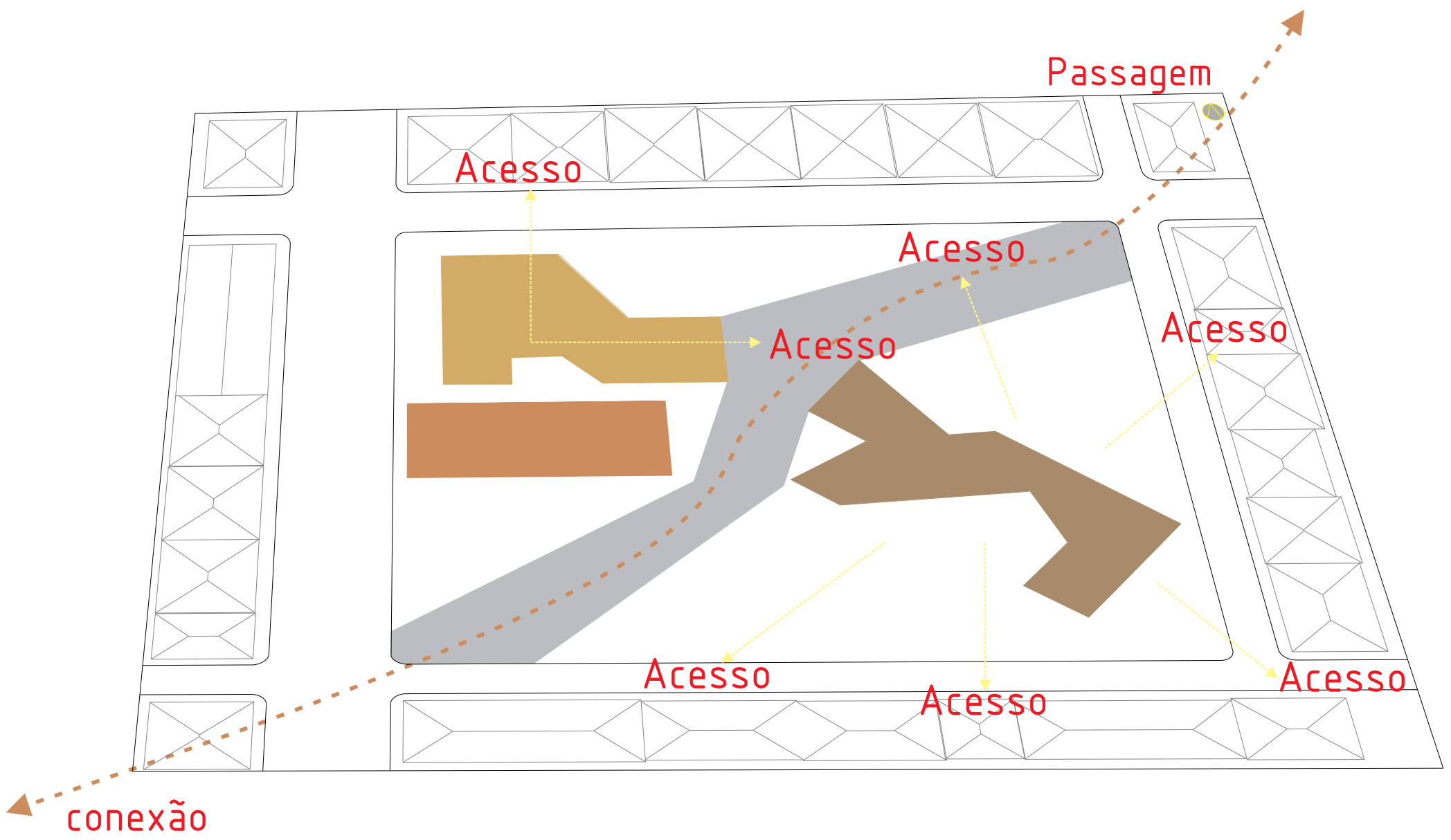

CONCEPÇÃO...

O PROJETO...

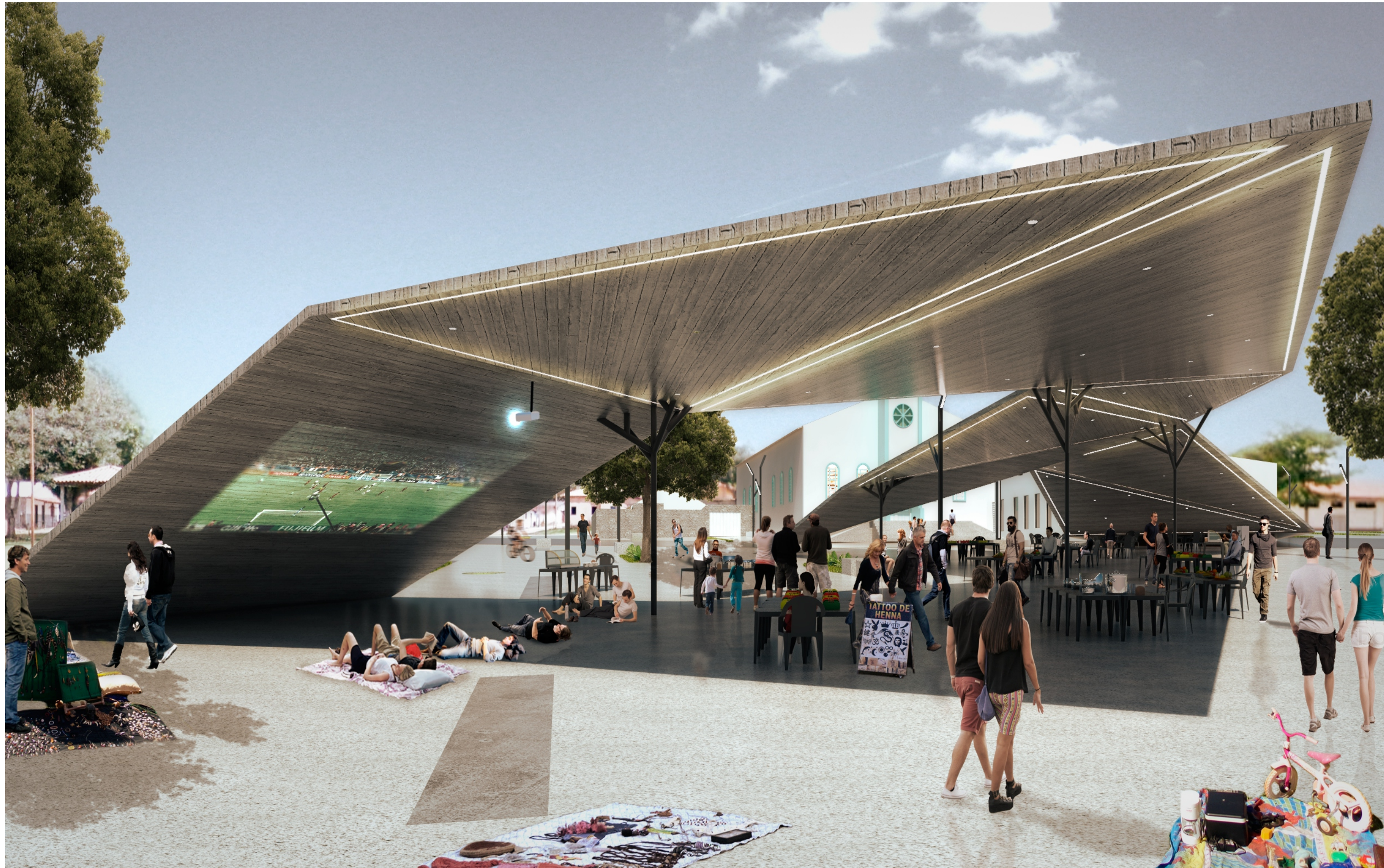

O PROJETO...



IMPLANTAÇÃO...

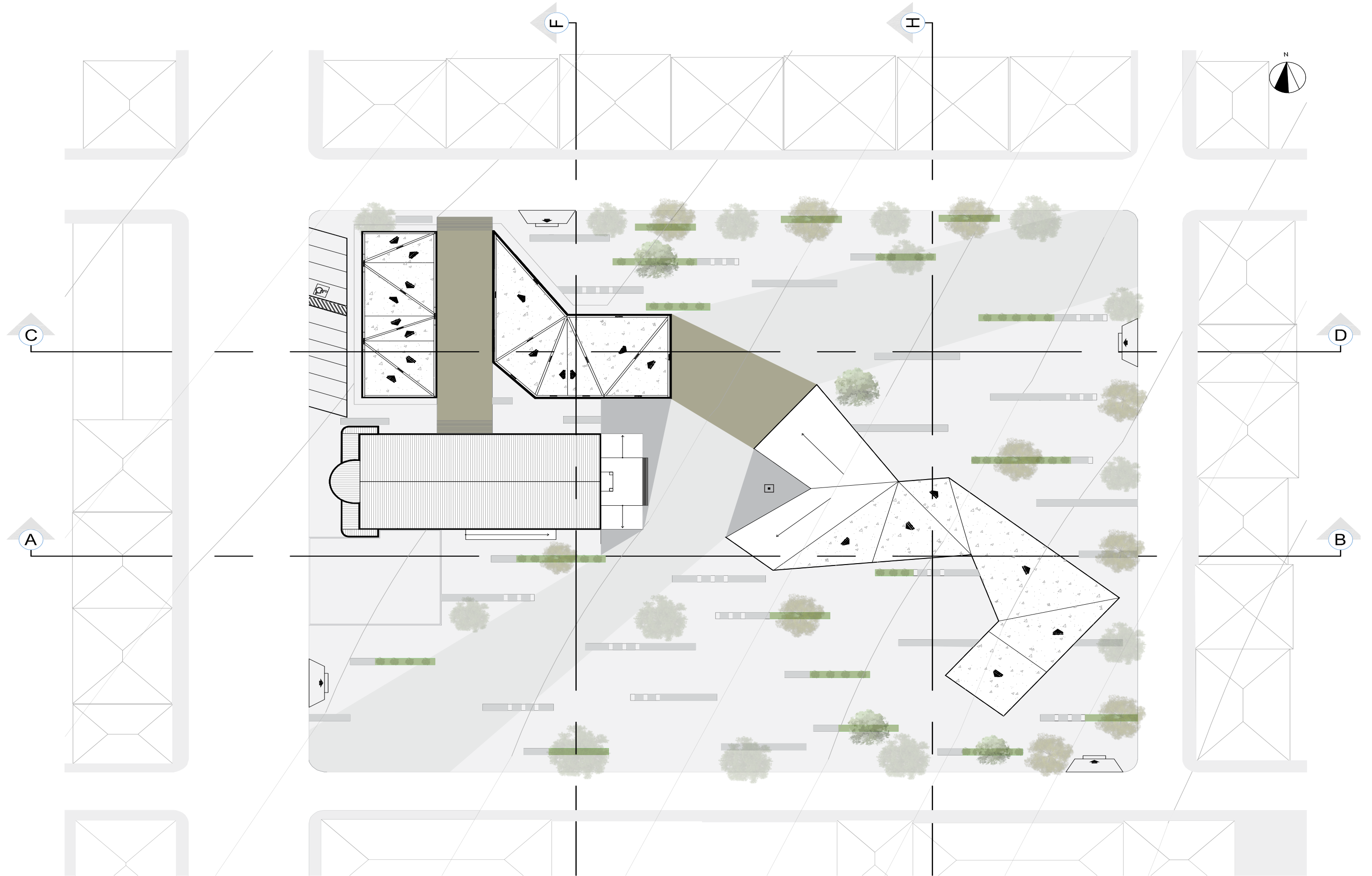

O PROJETO...



LEGENDA

1. Praça de alimentação
2. Balcão de informação
3. Lanchonetes
4. Secretária
5. Cozinha
6. Depósito
7. Banheiro masculino
8. Banheiro Feminino
9. Fraldário
10. Ateliê 01
11. Ateliê 02
12. Sala de aula
13. Passagem

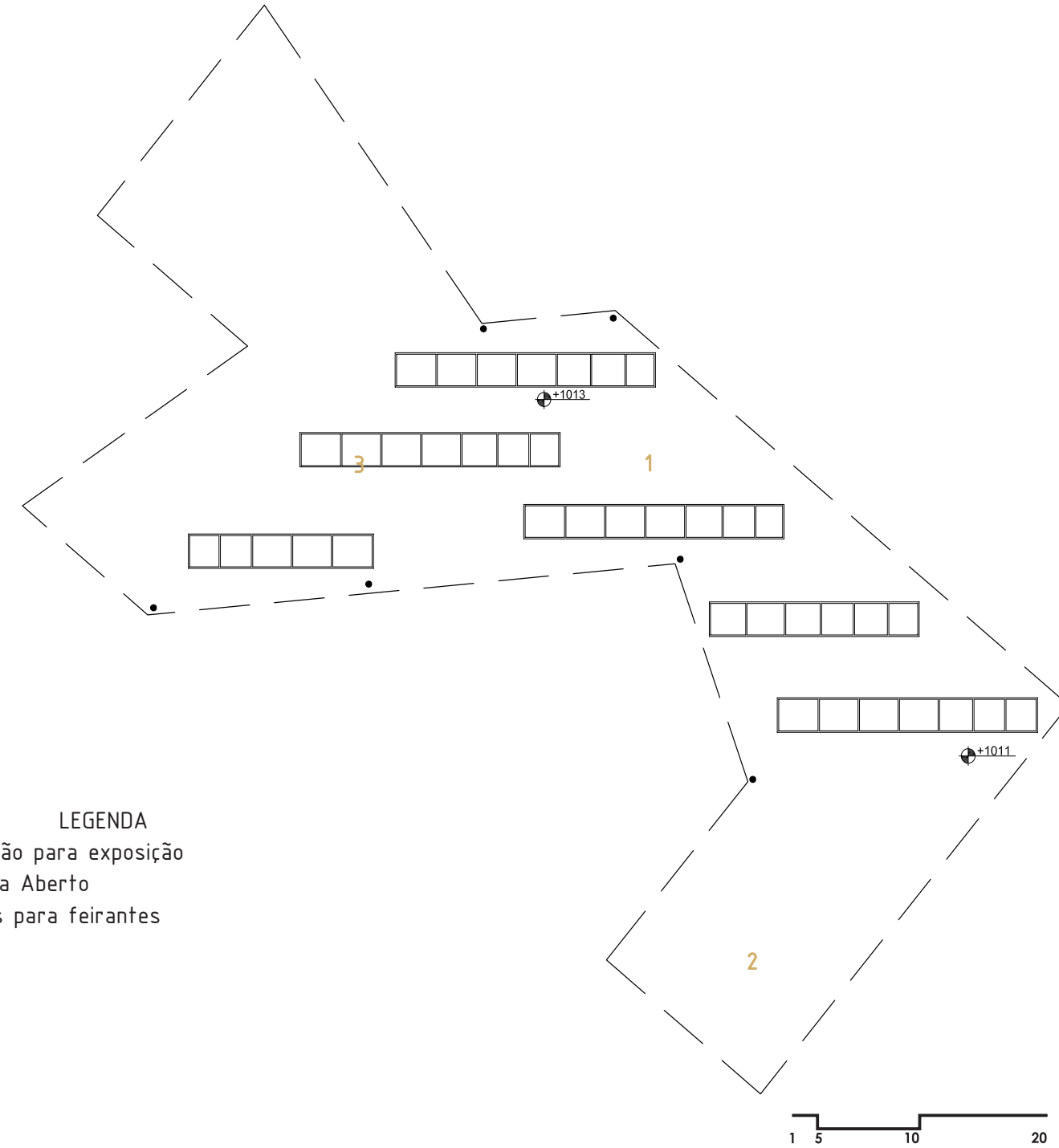

LEGENDA

1. Pavilhão para exposição
2. Cinema Aberto
3. Boxes para feirantes

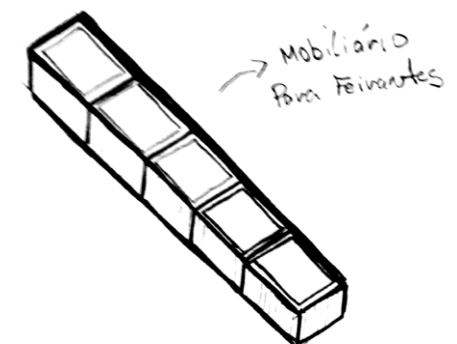
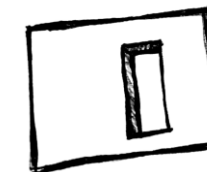
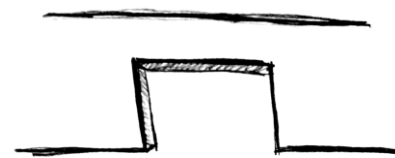
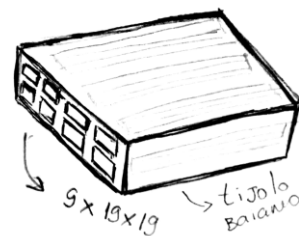
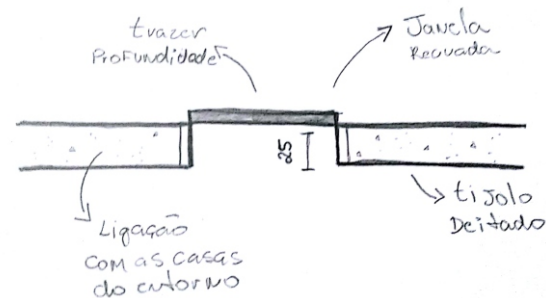

CORTES...

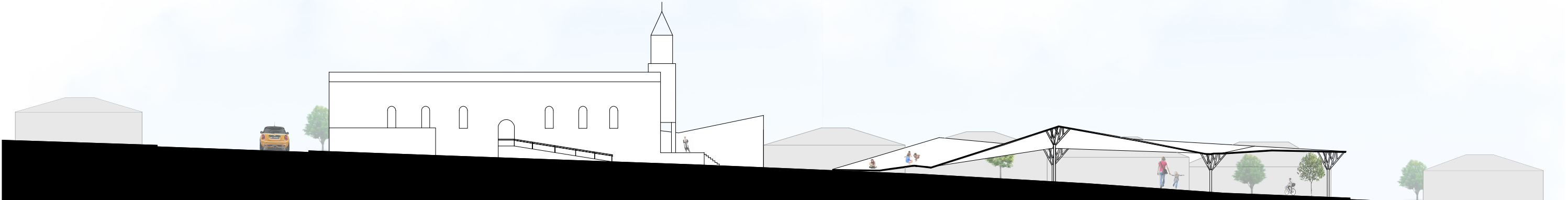
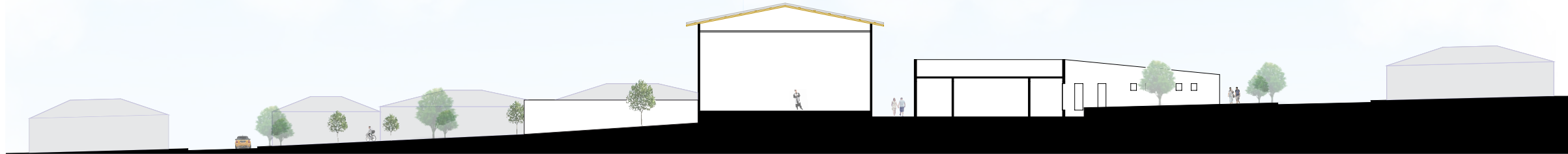





TECNOLOGIAS...

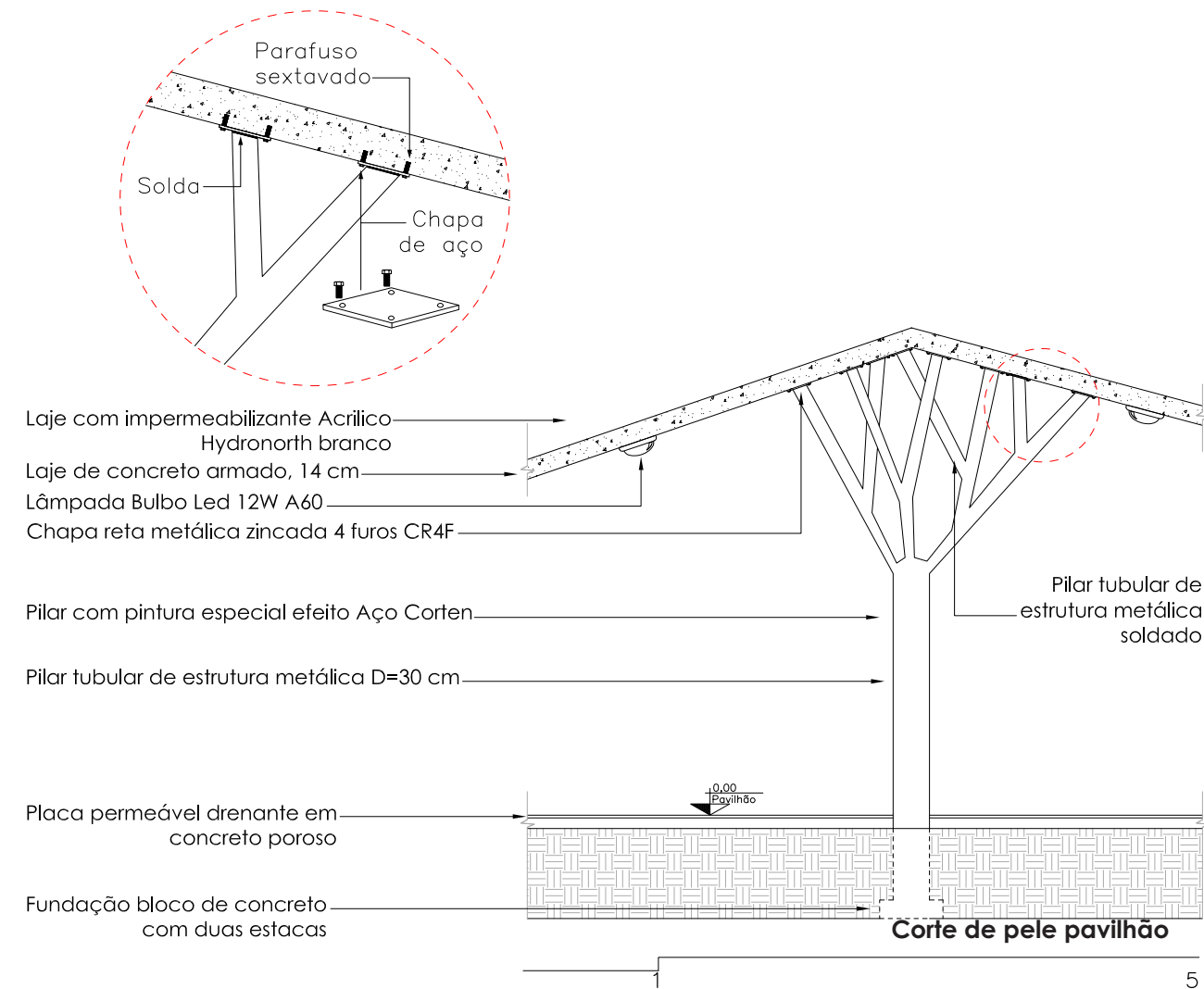
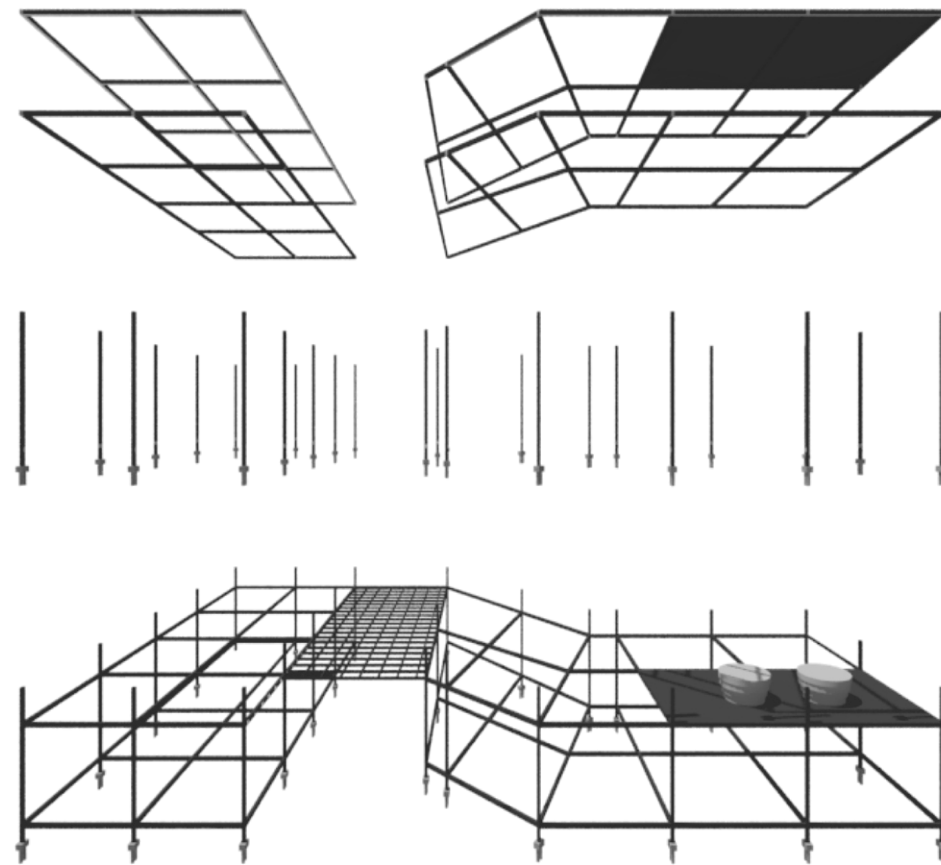

Nome científico: Tabebuia
Nome popular: Ipê
Tamanho: oito metros de altura



Nome científico: Licania tomentosa
Nome popular: Oiti, oitizeiro
Tamanho: entre oito e quinze metros de altura

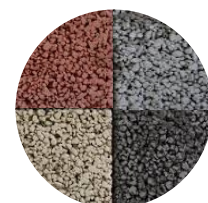

Concreto permeável colorido, utilizado na pavimentação da praça.



Réguas de concreto colorido cor cinza, utilizado no revestimento do pavilhão.



Nome científico: Buxus sempervirens
Nome popular: Buxinho
Tamanho: altura máxima de cinco metros



Nome científico: Chlorophytum cosmosum
Nome popular: Clorofito
Tamanho: 20 cm de altura



Pintura especial efeito aço corten, utilizado nos pilares metálicos do pavilhão.



Ripas de madeira de lei, utilizado em parte do piso da praça e na laje do pavilhão.

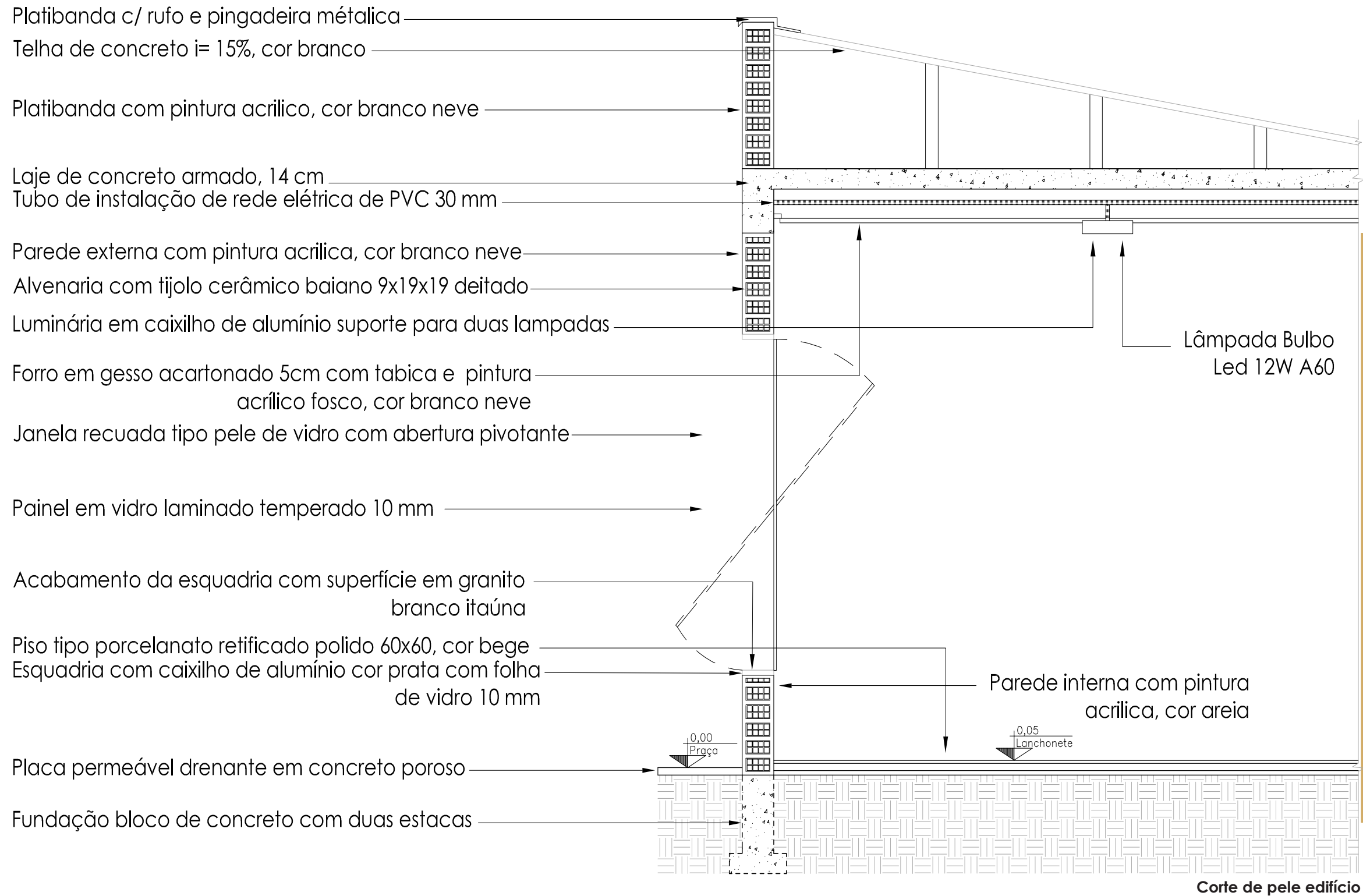

TECNOLOGIAS...

TECNOLOGIAS...

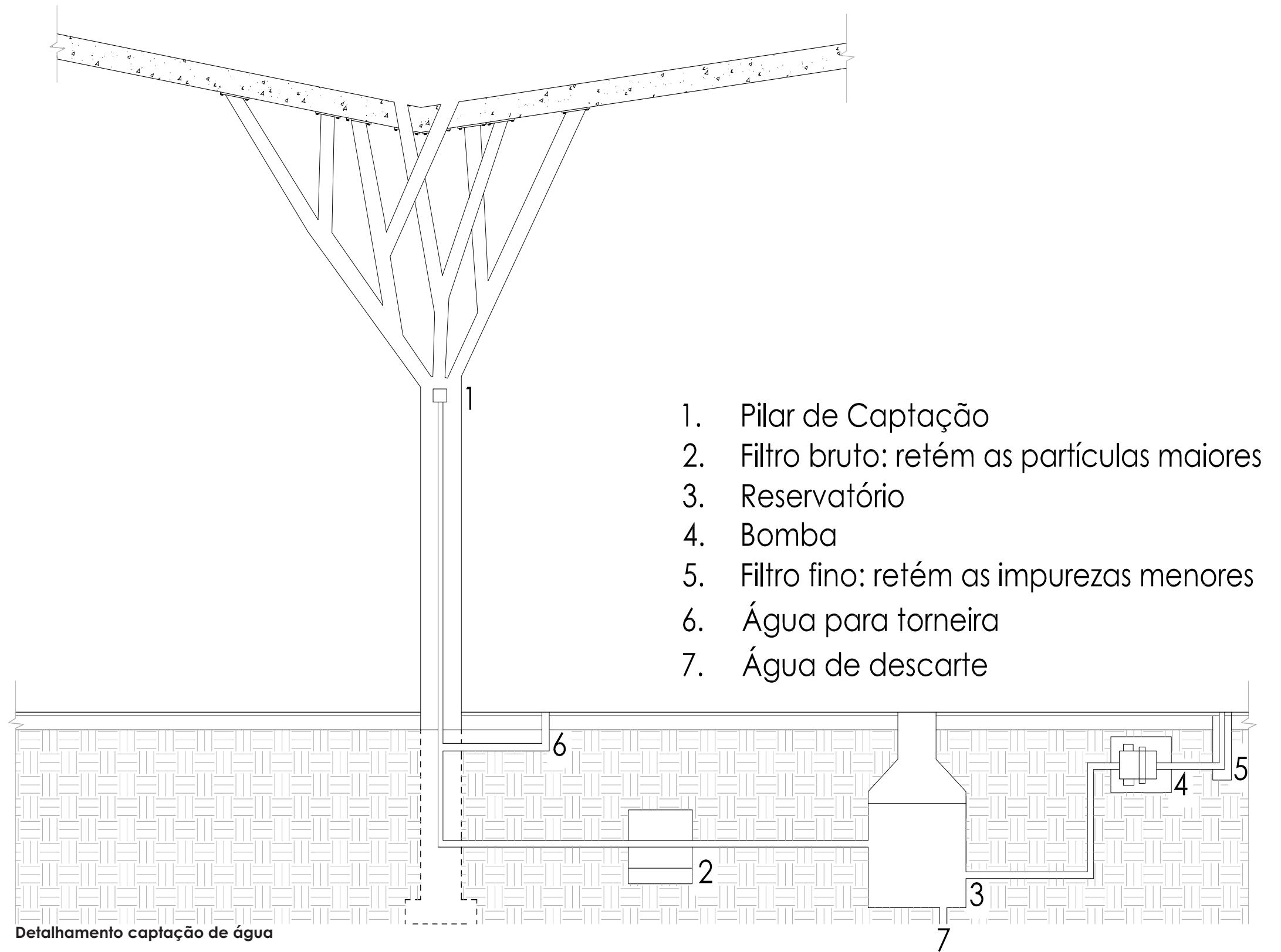



Acredito...

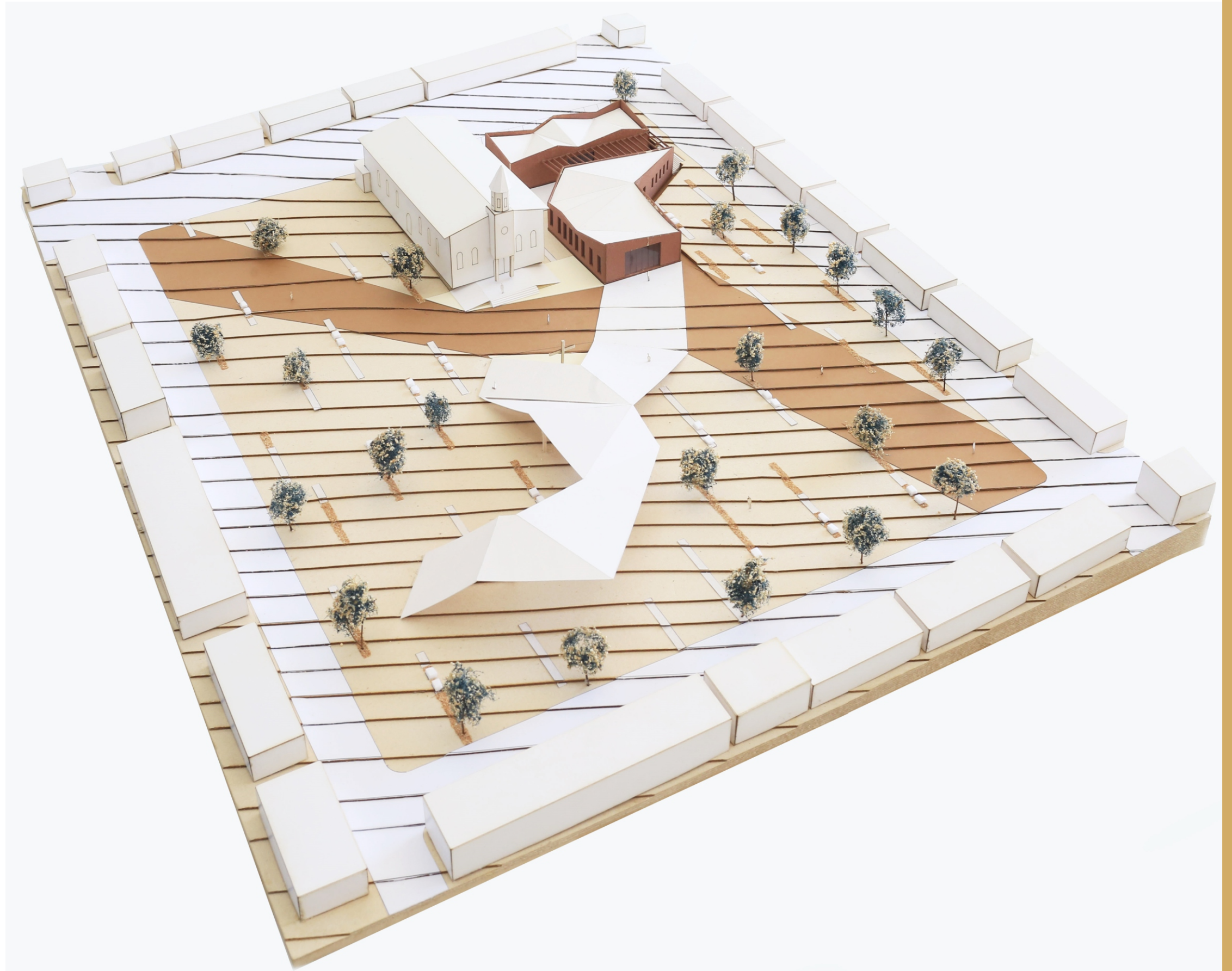

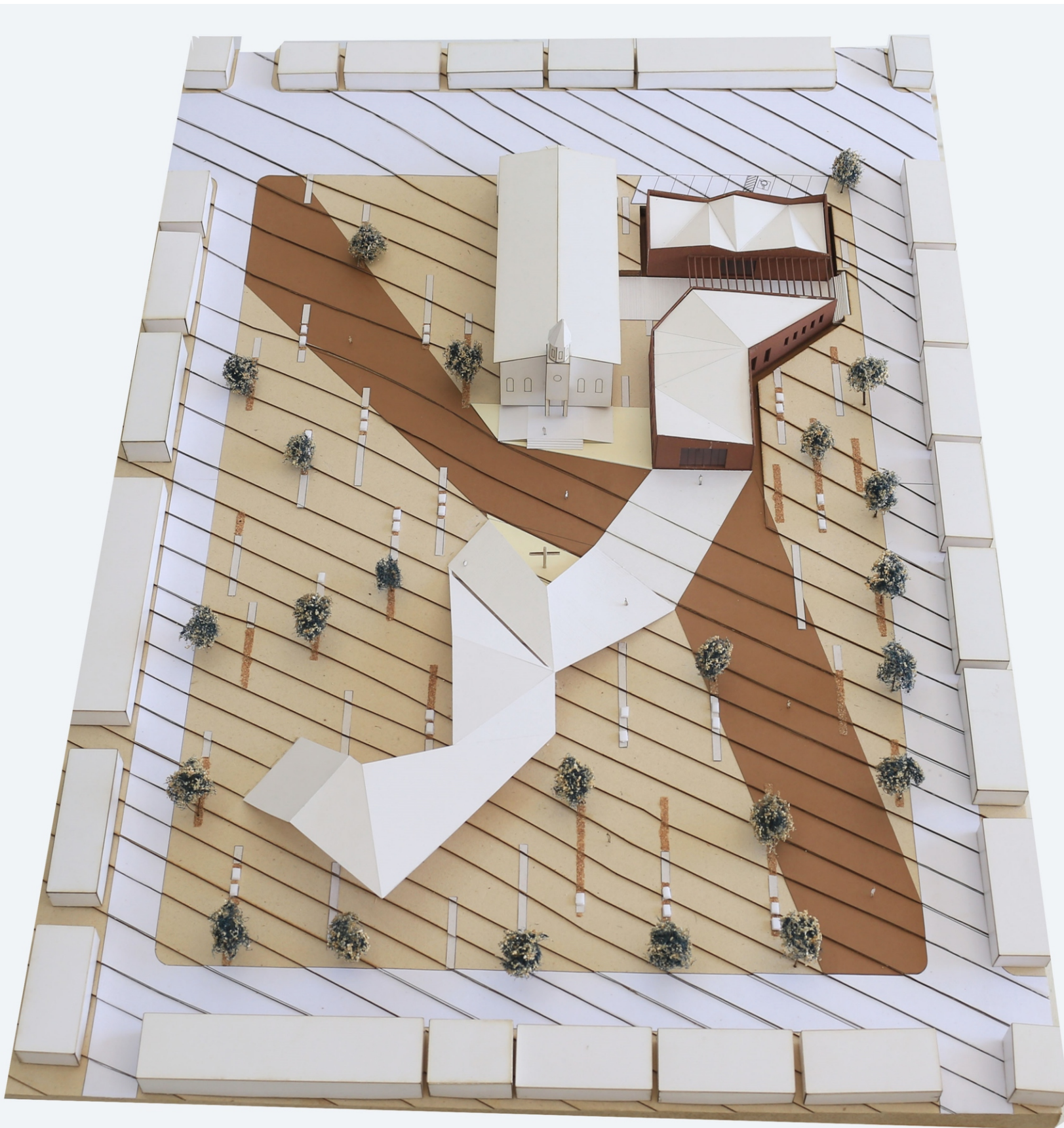

REFERÊNCIAS

LÓSSIO, Rúbia. Pereira, Cesar. **A importância da valorização da cultura popular para o desenvolvimento local.** Disponível em: http://www.cult.ufba.br/enecult2007/RubiaRibeiroLossio_CesardeMendoncaPereira.pdf. Acesso em: 23 de Agosto de 2016

CRAVEIRO, Rodrigo. **O vilarejo que respira arte.** Disponível em: http://sites.correioweb.com.br/app/noticia/encontro/revista/2013/05/08/interna_revista,648/o-vilarejo-que-respira-arte.shtml. Acesso em: 26 de Agosto de 2016

CASTRO, Janio. **O papel das manifestações culturais locais/ regionais no contexto da turistificação das festas juninas espetacularizadas em Cachoeira-BA.** Disponível em: <http://www.cult.ufba.br/enecult2009/19383.pdf>. Acesso em: 27 de Agosto de 2016

SILVA, Susie. **A importância das raízes culturais para a identidade cultural do indivíduo.** Disponível em: <http://meuartigo.brasilecola.uol.com.br/artes/a-importancia-das-raizes-culturais-para-identidade-.htm>. Acesso em: 26 de Agosto de 2016

LOPES, Diva. **Cidades médias e pequenas: teorias, conceitos e estudos de caso.** Disponível em: <http://www.redbcm.com.br/arquivos/bibliografia/cidades%20m%C3%A9dias%20e%20pequenas%20teorias,%20conceitos%20e%20estudos%20de%20caso.pdf>. Acesso em: 27 de Agosto de 2016

ABDALLAH, Alex. **Alexânia a cidade dos meus sonhos e a saga do seu fundador.** ALEXÂNIA, 2015



OBRIGADO...